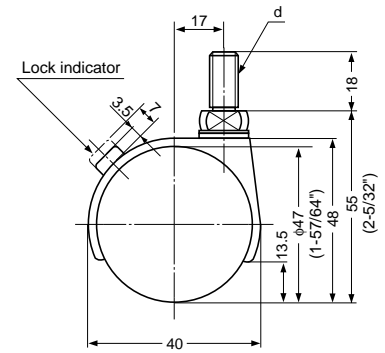
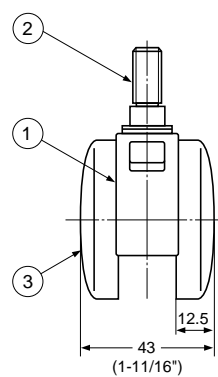
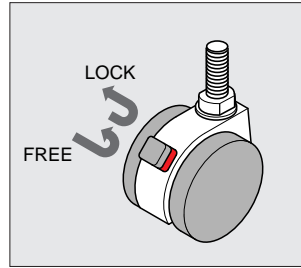

FA-45 SERIES TWIN WHEEL CASTER THREADED BOLT TYPE

LOAD CAPACITY
 50kg
 110lbs
FA-45-N
(w/o Brake)FA-45-NS
(w/ Brake)

No.	Part Name	Material	Finish
①	Body	Aluminum Alloy	Silver
②	Threaded Bolt	Steel	Yellow Zinc Chromate
③	Wheel	Polyamide	Black

Item No.	d	Load Capacity (kg)	Weight (g)	Box (pcs)	Carton (pcs)
FA-45-NS	W3/8-16UNC	50 (110 lbs)	100	4	100
FA-45-N	M10x1.5	50 (110 lbs)	97	4	100

FP-45 SERIES TWIN WHEEL CASTER THREADED BOLT TYPE

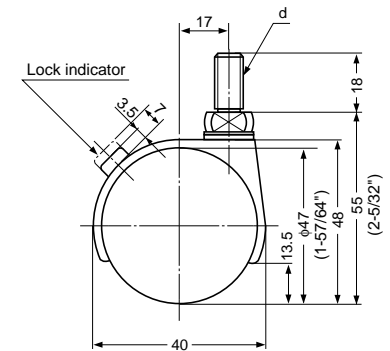
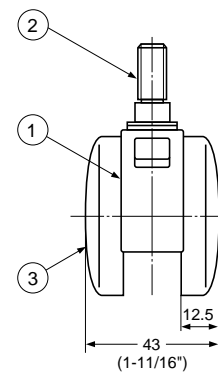
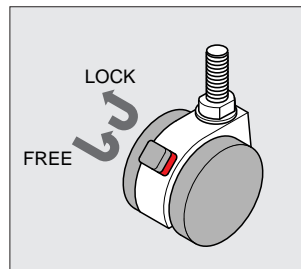
LOAD CAPACITY
 40kg
 88lbs
FP-45-N3
(w/o Brake)FP-45-N3S
(w/ Brake)

No.	Part Name	Material	Finish
①	Body	Polyamide	Black
②	Threaded Bolt	Steel	Yellow Zinc Chromate
③	Wheel	Polyamide	Black

Item No.	d	Load Capacity (kg)	Weight (g)	Box (pcs)	Carton (pcs)
FP-45-NS	W3/8-16UNC	40 (88 lbs)	84	4	100
FP-45-N	M10x1.5	40 (88 lbs)	79	4	100